



ELECTRONICS

# USER GUIDE

## iRZ GSM/3G/LTE Routers:

### RL01w, RU01w





## Table of Contents

<b>1. Introduction .....</b>	<b>4</b>
1.1.Document Description .....	4
<b>2. Information on Device.....</b>	<b>5</b>
2.1.Purpose.....	5
2.2.Application.....	5
2.3.Model Range.....	6
2.4.Specifications .....	6
2.5.Complete Set .....	7
2.6.Storage and Operating Conditions .....	7
2.7.Safety Precautions .....	8
<b>3. Appearance and Interfaces .....</b>	<b>9</b>
3.1.Appearance.....	9
3.2.Interfaces .....	11
3.3.Router Indication .....	13
3.4.Settings Access.....	14
<b>4. Contacts and Support.....</b>	<b>15</b>



## List of Tables

Table 2.1 Models and Basic Differences.....	6
Table 2.2 Basic Specifications .....	6
Table 2.3 Scope of Supply .....	7
Table 2.4 Recommended Optional Accessories .....	7
Table 3.1 Power Connector Pin Assignment .....	11
Table 3.2 Ethernet Connector Pin Assignment .....	12
Table 3.3 Connector Assignment .....	13
Table 3.4 Router Indication .....	13

## List of Figures

Figure 1. Front View (RL01w, RU01w) .....	9
Figure 2. Top View .....	10
Figure 3. Power Connector .....	11
Figure 4. Ethernet Connector .....	12



# 1. Introduction

## 1.1. Document Description

This document is intended for advanced users and describes technical specifications of R0 series routers: RU01w, RL01w as well as information on express setting of the routers.

Document Version		Issue Date	
1.0		08/11/2016	
1.1 (route parameter updated)		09/02/2017	
1.1.1 (3.2 – Reset button)		27/04/2017	
1.2 (2.2 – new functions added)		28/04/2017	
1.3 (3.2 – power and Ethernet connector pin assignment)		02/08/2017	
1.4 (2.1, 2.4, 2.6, 3.2)		25/12/2018	
2.0 (model range)		21/03/2019	
<b>Prepared by:</b>	O. Kolmak, T. Yakovleva	<b>Checked by:</b>	O. Kolmak



## 2. Information on Device

### 2.1. Purpose

iRZ R0 routers are compact routers supporting two SIM cards to be used for operation in 3G (**RU01w**, **RL01w**) and 4G (**RL01w**) networks. They provide high-speed wireless connection to the Internet (100/50 and 14.4/5.76 Mbps in 4G and 3G networks, respectively) and processor integrated 802.11b/g/n 2T2R support.

The core is a high performance MIPS processor with low power consumption. The router is controlled by the Linux kernel based OpenWRT operating system for high performance and uninterrupted operation. The software platform allows for expanding the router functionalities with user scripts and additional software packages.

### 2.2. Application

The routers of this series are used for high-speed wireless or wired connection of point-of-sale terminals and ATMs with control center, remote branch offices with the head office, industrial equipment units, security and CCTV, monitoring and control systems, and other systems which require a wireless communication channel.

Basic functionalities of iRZ R0 routers:

- APN automatic detection
- NAT configuration for access to internal network resources from outside
- Exact time service server and client
- Operations, administration and maintenance via Web-interface
- Wi-Fi Internet access restriction by means of MAC filtering
- OpenVPN tunnel support
- GRE tunnel support
- DHCP Server
- PPTP Client
- Firewall

The list of functionalities will be expanded with internal software improvements.



## 2.3. Model Range

The **iRZ R0** routers differ in communication modules (3G and 4G functionality).

**Table 2.1** Models and Basic Differences

Model	Communication module	Wi-Fi support
RU01w	3G	Yes
RL01w	4G	Yes

## 2.4. Specifications

**Table 2.2** Basic Specifications

Type	Characteristic
<b>Hardware Specifications</b>	
Processor	MIPS24KEc (580 MHz)
Dynamic RAM	64 MB
Flash memory	16 MB
SIM card	Dual SIM support
Ethernet connector	1 x Ethernet 10/100 Mbit
Wi-Fi	2.4 GHz 802.11 b/g/n 2T2R MAC
Communications standards supported	<ul style="list-style-type: none"><li>• LTE**</li><li>• DC-HSPA+**</li><li>• UMTS</li><li>• EDGE</li><li>• GPRS</li></ul>
<b>Power Supply</b>	
Supply voltage	8 to 30 V
Current consumption	500 mA at 12 V
	250 mA at 24 V
<b>Physical Specifications</b>	
Case material	Plastic
Dimensions	123 x 86 x 25 mm
Weight	Max. 150 g
Operating temperature range	-40°C to 65°C

\*\* For RL01w only



## 2.5. Complete Set

**Table 2.3** Scope of Supply

Description
Router
Manufacturer's packing

**Table 2.4** Recommended Optional Accessories

Description
Power supply unit, 1000 mA, 6P6C connector
2 x SMA GSM antenna
2 x RP-SMA Wi-Fi antenna
Network cable

## 2.6. Storage and Operating Conditions

The router shall be stored in a dry place, protected against water. The risk of static voltage (lightning, household static electricity) shall be eliminated.

Rating of ingress protection is IP20 per GOST 14254-96.

Permissible vibration:

The router maintains its strength characteristics under mechanical loads corresponding to 15th grade of sinusoidal vibration severity per GOST 30631-99: as a part of equipment operated in motion, installed on tractors, tracked vehicles and water transport (speed boats, hydrofoil vessels, etc.) and on process equipment or land transport, in case vibration frequency exceeds 80 Hz.

The router is not provided with any vibration isolation.



## 2.7. Safety Precautions

Limitations to the router use in proximity of other electronic devices:

- Switch off the router in hospitals or in proximity of medical equipment (like cardiac pacemakers, hearing aid devices) as it may interfere with medical equipment.
- Switch off the router in aircraft and take measures to prevent its accidental switching on.
- Switch off the router in proximity of fueling stations, chemical facilities, areas of blasting operations. The router may interfere with equipment; at short distances it may also interfere with TV and radio sets.

Protect the router against dust and moisture.

Observe the permissible levels of power supply and vibration at the place of router installation.





### 3. Appearance and Interfaces

#### 3.1. Appearance

The router is designed in a compact plastic case.

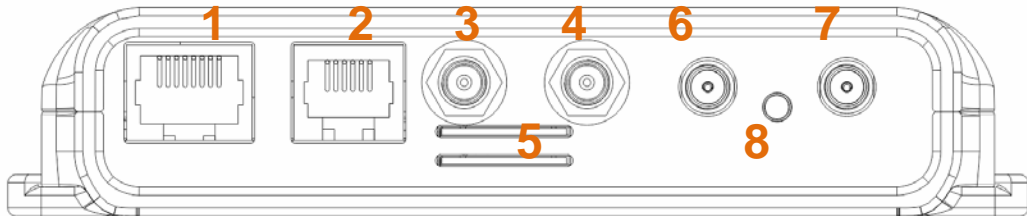

**Figure 1.** Front View (RL01w, RU01w)

Legend for Figure 1:

1. Ethernet connector
2. Power Connector
3. Wi-Fi Connector 2
4. Wi-Fi Connector 1
5. SIM-card slots No.1 and No.2
6. GSM Aux connector
7. GSM Main connector
8. Reset button

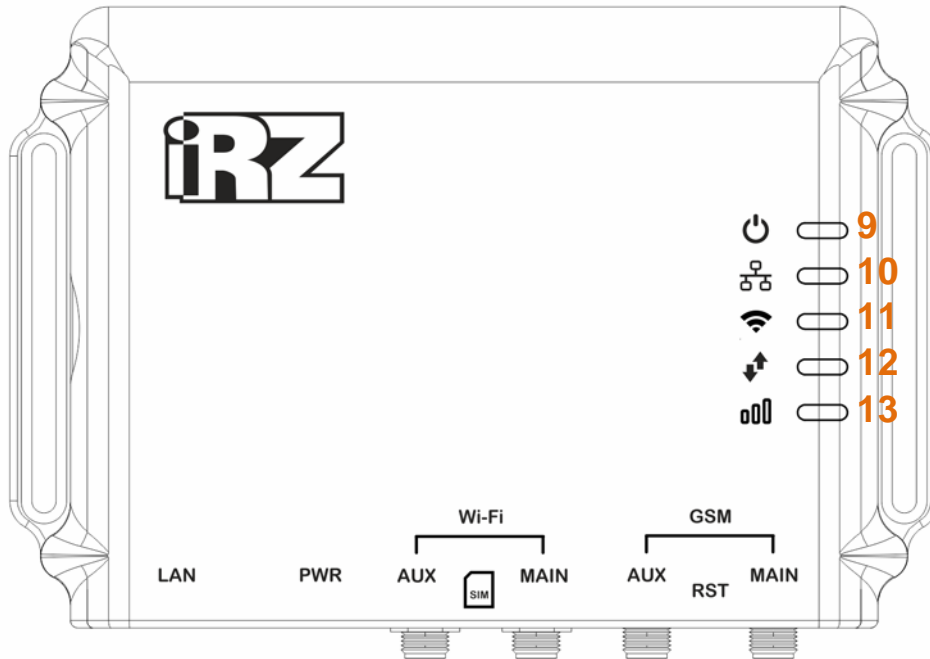

**Figure 2. Top View**

Legend for Figure 2:

- 9. Power and boot indicator
- 10. Ethernet indicator
- 11. Wi-Fi indicator
- 12. Wireless connection type indicator
- 13. Signal level indicator



## 3.2. Interfaces

### Power

The power interface is represented by the 6P6C connector which feeds the router from a DC source. The supply voltage is in the range of 8 to 30 V.

The current consumption is max. 500 mA at 12 V and max. 250 mA at 24 V.

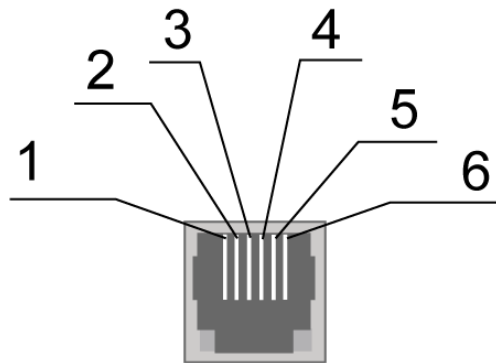

**Figure 3.** Power Connector

**Table 3.1** Power Connector Pin Assignment

Contact	Signal	Purpose
1	+U <sub>pwr</sub>	DC supply voltage positive Protected by a fuse and overvoltage (input voltage >30 V) and reverse polarity protection circuit
2	Not used	–
3	Not used	–
4	Not used	–
5	Not used	–
6	GND	Router chassis (negative)

### Ethernet

The Ethernet interface is designed to configure the router, to monitor its status, and to have access to the Internet. One 10/100 Mbit/s port is available.

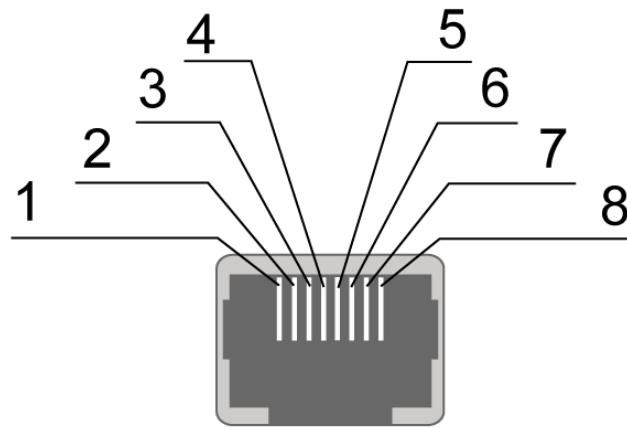

**Figure 4.** Ethernet Connector

**Table 3.2** Ethernet Connector Pin Assignment

Contact	Signal	Direction	Purpose
1	ETX P	Router → PC	Transmission positive
2	ETX N	Router → PC	Transmission negative
3	ERX P	PC → Router	Reception positive
4	Not used	–	–
5	Not used	–	–
6	ERX N	PC → Router	Reception negative
7	Not used	–	–
8	Not used	–	–

### **SIM Interface**

The SIM interface is designed to insert SIM-cards in the router. It is designed as a SIM card slot.

Prior to supplying power, insert a SIM card in the router. Proceed as follows:

- Insert SIM card into the slot to click.
- To extract the SIM card, press it to click and release.

### **Reset Button**

The Reset button is designed to reset the device to factory settings. If the router's interface can not be accessed due to incorrect settings or the password is forgotten, press and hold the Reset button for 10 seconds to restore the factory settings. The power indicator will blink green with a 1-second interval. If the Reset button is held for just 5 seconds, the router will reboot without resetting.



## Antenna connectors

















**Table 3.3** Connector Assignment

Connector	Connector type	Purpose
GSM M	SMA Female	Used to connect the router's main antenna
GSM A	SMA Female	Used to connect the router's auxiliary antenna
Wi-Fi 1	RP-SMA Female	Used to connect the router's main Wi-Fi antenna
Wi-Fi 2	RP-SMA Female	Used to connect the router's auxiliary Wi-Fi antenna

### 3.3. Router Indication

Router indicators are located at the top of the case.

**Table 3.4** Router Indication

Symbol	Status	Purpose
Router operation indication		
 Power	 (green) Lights	After power on or during operation
	 (green) Blinking	Booting, reset, software update
 Ethernet	 (green) Lights	Connection established
	 (green) Blinking	Transmit data
 Wi-Fi	 (green) Lights	Wi-Fi active
	 (green) Blinking	Transmit data
 Connection	<input type="checkbox"/> (off)	No connection established.
	 (green)	2G
	 (dark blue)	3G
	 (blue)	4G
 Signal	<input type="checkbox"/> (off)	GSM module off
	 (red)	Poor signal
	 (yellow)	Good signal
	 (green)	Excellent signal



### 3.4. Settings Access

1. Connect the power supply unit to the power connector.
2. Connect LAN cable to the LAN port.
3. Wait until router boots up and the **Power** indicator stops blinking.
4. Go to <http://192.168.1.1> in your browser.
5. To access the web-interface, enter username **root** and password **root**.



## 4. Contacts and Support

To obtain new versions of firmware, documents and respective software, contact us using the details below:

St. Petersburg	
Company website:	<a href="http://www.radiofid.ru">www.radiofid.ru</a>
Contact phone in St. Petersburg:	+7 (812) 318 18 19
e-mail:	<a href="mailto:support@radiofid.ru">support@radiofid.ru</a>

Our specialists are always ready to answer all your questions and assist in installing, configuring or troubleshooting of your equipment.

In case of any problem, contact the technical support service and specify the router software version. It is also recommended to attach any problematic service startup logs, configuration screenshots and any other relevant information to your letter. The more information you provide to the technical support specialist, the less time it will take to handle the situation.

**Note:** It is strongly recommended to update the router software to the current version prior to contacting the technical support service.

**Warning!** Failure to observe the operation conditions (improper use of the router) will make the warranty null and void.